



IBM STG Technical Sales System z

Neues von IBM z10 BC, z/VSE und z/VM

Course Tagung Fa. Lattwein Köln
18-19.05.2009

Joerg Haertel
IBM STG FTSS GB
Senior IT Specialist
Email : haertel@de.ibm.com
Telefon : 089 4504 3240



Trademarks

The following are trademarks of the International Business Machines Corporation in the United States and/or other countries.

AlphaBlox*	GDPS*	RACF*	Tivoli*
APPN*	HiperSockets	Redbooks*	Tivoli Storage Manager
CICS*	HyperSwap	Resource Link	TotalStorage*
CICS/VSE*	IBM*	RETAIN*	VSE/ESA
Cool Blue	IBM eServer	REXX	VTAM*
DB2*	IBM logo*	RMF	WebSphere*
DFSMS	IMS	S/390*	xSeries*
DFSMSHsm	Language Environment*	Scalable Architecture for Financial Reporting	z9*
DFSMSrmm	Lotus*	Sysplex Timer*	z10
DirMaint	Multiprise*	Systems Director Active Energy Manager	z10 BC
DRDA*	MVS	System/370	z10 EC
DS6000	OMEGAMON*	System p*	z/Architecture*
DS8000	Parallel Sysplex*	System Storage	z/OS*
ECKD	Performance Toolkit for VM	System x*	z/VM*
ESCON*	PowerPC*	System z	z/VSE
FICON*	PR/SM	System z9*	zSeries*
FlashCopy*	Processor Resource/Systems Manager	System z10	

* Registered trademarks of IBM Corporation

The following are trademarks or registered trademarks of other companies.

Adobe, the Adobe logo, PostScript, and the PostScript logo are either registered trademarks or trademarks of Adobe Systems Incorporated in the United States, and/or other countries.

Cell Broadband Engine is a trademark of Sony Computer Entertainment, Inc. in the United States, other countries, or both and is used under license therefrom.

Java and all Java-based trademarks are trademarks of Sun Microsystems, Inc. in the United States, other countries, or both.

Microsoft, Windows, Windows NT, and the Windows logo are trademarks of Microsoft Corporation in the United States, other countries, or both.

Intel, Intel logo, Intel Inside, Intel Inside logo, Intel Centrino, Intel Centrino logo, Celeron, Intel Xeon, Intel SpeedStep, Itanium, and Pentium are trademarks or registered trademarks of Intel Corporation or its subsidiaries in the United States and other countries.

UNIX is a registered trademark of The Open Group in the United States and other countries.

Linux is a registered trademark of Linus Torvalds in the United States, other countries, or both.

ITIL is a registered trademark, and a registered community trademark of the Office of Government Commerce, and is registered in the U.S. Patent and Trademark Office.

IT Infrastructure Library is a registered trademark of the Central Computer and Telecommunications Agency, which is now part of the Office of Government Commerce.

* All other products may be trademarks or registered trademarks of their respective companies.

Notes:

Performance is in Internal Throughput Rate (ITR) ratio based on measurements and projections using standard IBM benchmarks in a controlled environment. The actual throughput that any user will experience will vary depending upon considerations such as the amount of multiprogramming in the user's job stream, the I/O configuration, the storage configuration, and the workload processed. Therefore, no assurance can be given that an individual user will achieve throughput improvements equivalent to the performance ratios stated here.

IBM hardware products are manufactured from new parts, or new and serviceable used parts. Regardless, our warranty terms apply.

All customer examples cited or described in this presentation are presented as illustrations of the manner in which some customers have used IBM products and the results they may have achieved. Actual environmental costs and performance characteristics will vary depending on individual customer configurations and conditions.

This publication was produced in the United States. IBM may not offer the products, services or features discussed in this document in other countries, and the information may be subject to change without notice. Consult your local IBM business contact for information on the product or services available in your area.

All statements regarding IBM's future direction and intent are subject to change or withdrawal without notice, and represent goals and objectives only.

Information about non-IBM products is obtained from the manufacturers of those products or their published announcements. IBM has not tested those products and cannot confirm the performance, compatibility, or any other claims related to non-IBM products. Questions on the capabilities of non-IBM products should be addressed to the suppliers of those products.

Prices subject to change without notice. Contact your IBM representative or Business Partner for the most current pricing in your geography.

IBM z10 BC continues the CMOS Mainframe heritage

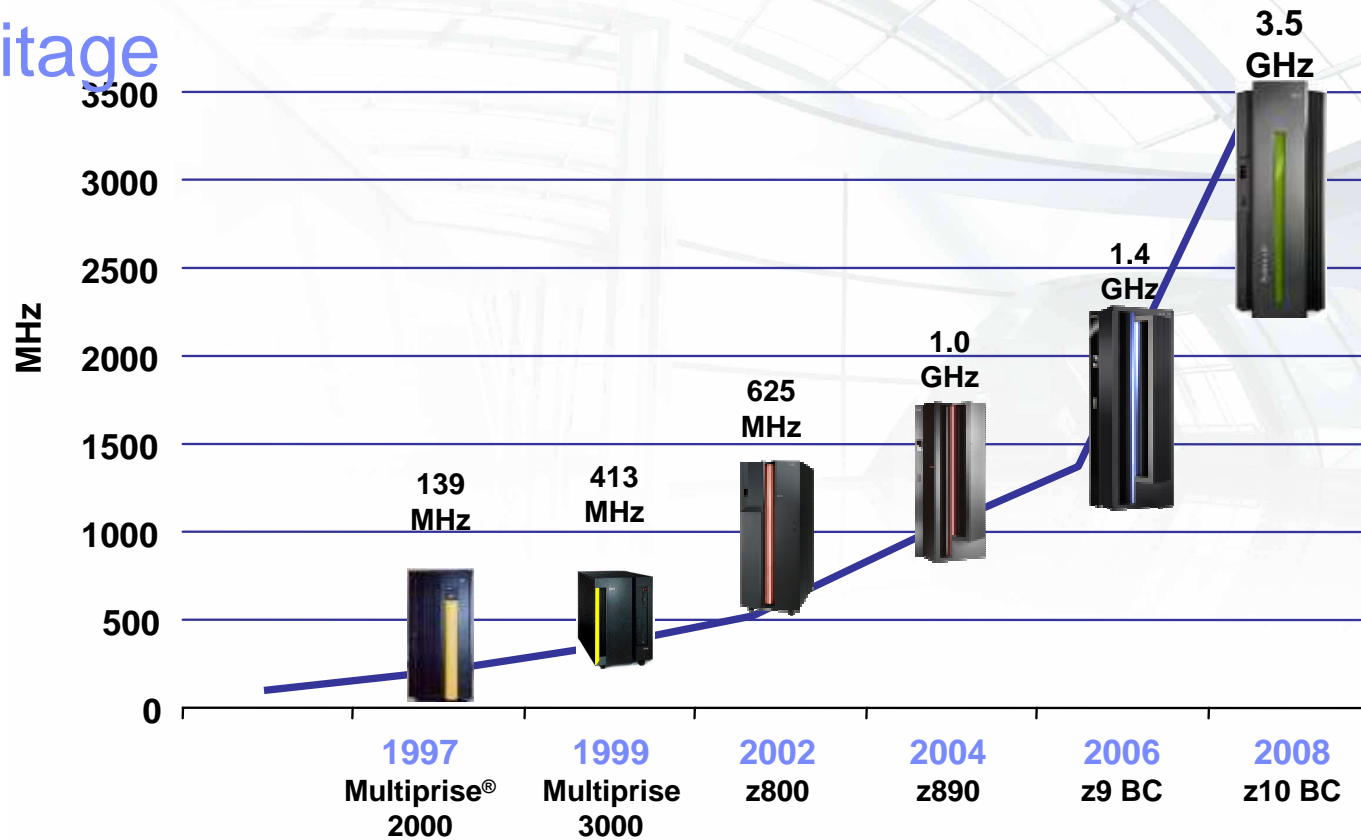

- Multiprise 2000 – 1st full-custom Mid-range CMOS S/390
- Multiprise 3000 – Internal disk, IFL introduced on midrange

- IBM eServer zSeries 800 (z800) - Full 64-bit z/Architecture[®]
- IBM eServer zSeries 890 (z890) - Superscalar CISC pipeline
- z9 BC - System level scaling

- z10 BC - Architectural extensions
- Higher frequency CPU



z10 BC Configuration Comparisons

	z9 BC R07	z9 BC S07	z10 BC E10	z10 EC E12
Uniprocessor Performance	470 MIPS		673 MIPS	920 MIPS
System Capacity	26-172 MIPS	193-1748 MIPS	26-2760 MIPS	218-8225 MIPS
System Memory (with HSA)	Up to 64 GB	Up to 64 GB	Up to 256 GB (06/09)	Up to 384 GB
Configurable Engines	7	7	10	12
Configurable CPs	1-3	0-4	0-5	0-12
LPARS/LCSS	15/1	30/2	30/2	60/4
HiperSockets	16		16	16
I/O Cages/Drawers	1	1	Up to 4	Up to 3
I/O slots per Cage/Drawers	16	28	8	28
FICON Channels	64	112	128	256
OSA Ports (10GbE/1GbE)	16/32	24/48	48/96	48/96
ESCON Channels	240	420	480	960
STI (z9), IFB (z10) Bandwidth	2.7 GB/sec		6.0 GB/sec	6.0 GB/sec
ICB-4/ISC-3/12x/1xPSIFB	16/48/12 for CF Only Model/0		12/48/12/12	16/48/16/16
zIIP/zAAP Maximum Qty	3	3	5	6
Capacity Settings	20	53	130	48
Upgradeable	Upgrade to z9 S07 and z10 BC	Upgrade to z9 EC & z10 BC	Upgrade to z10 EC, Model E12	Upgrade to z10 EC Models E26, E40, E56 and E64

z10 BC – Functions and Features Overview - 1

- One Hardware Model
- New CPC and I/O Drawers
- Faster Uni Processor – 3.5 Ghz
- Up to 5 CPs
- 130 CP Capacity Settings
- Replaceable Processor Unit and System Controller Single Chip Modules (SCMs)
- Up to 120 GB Customer Memory (248 GB, June 30, 2009)
- Separate 8 GB of fixed HSA
- HiperDispatch
- Capacity Provisioning Support
- Large Page Support (1 MB)
- Hardware Decimal Floating Point



- Hot Pluggable I/O Drawer
- InfiniBand® (IFB) I/O interconnect
- InfiniBand Coupling Links
- STP over Coupling Links including InfiniBand
- FICON Express4 Performance Improvement
- New Family of OSA-Express3
- HiperSockets Layer 2 Support
- Enhanced CPACF with SHA 512, AES 192 and 256-bit keys
- CBU & On/Off CoD Increased Functionality and Flexibility
- Scheduled Outage Reduction
- Improved RAS
- Power Monitoring Support

No support for Japanese Compatibility Mode (JCM)
 No support for MVS™ Assist instructions

z10 BC – Functions and Features Overview – 2

- Plan Ahead memory
- Capacity Provisioning Enhancements – Capacity Tokens
- Run production workload with CBU test. T & Cs apply
- LPAR Dynamic PU reassignment
- Change weights of LPARs
- CPU Measurement Facility
- HMC Console Messenger
- HMC and z/VM System Management



- NTP Server on HMC
- CFCC Level 16
- STP Enhancements
- PSIFB replacement for ISC-3
- High Performance FICON for System z
- Crypto TKE 5.3 Enhancements
- z/VM Image Mode
- OSA QDIO Connection Isolation



z10 BC – Under the covers Front View

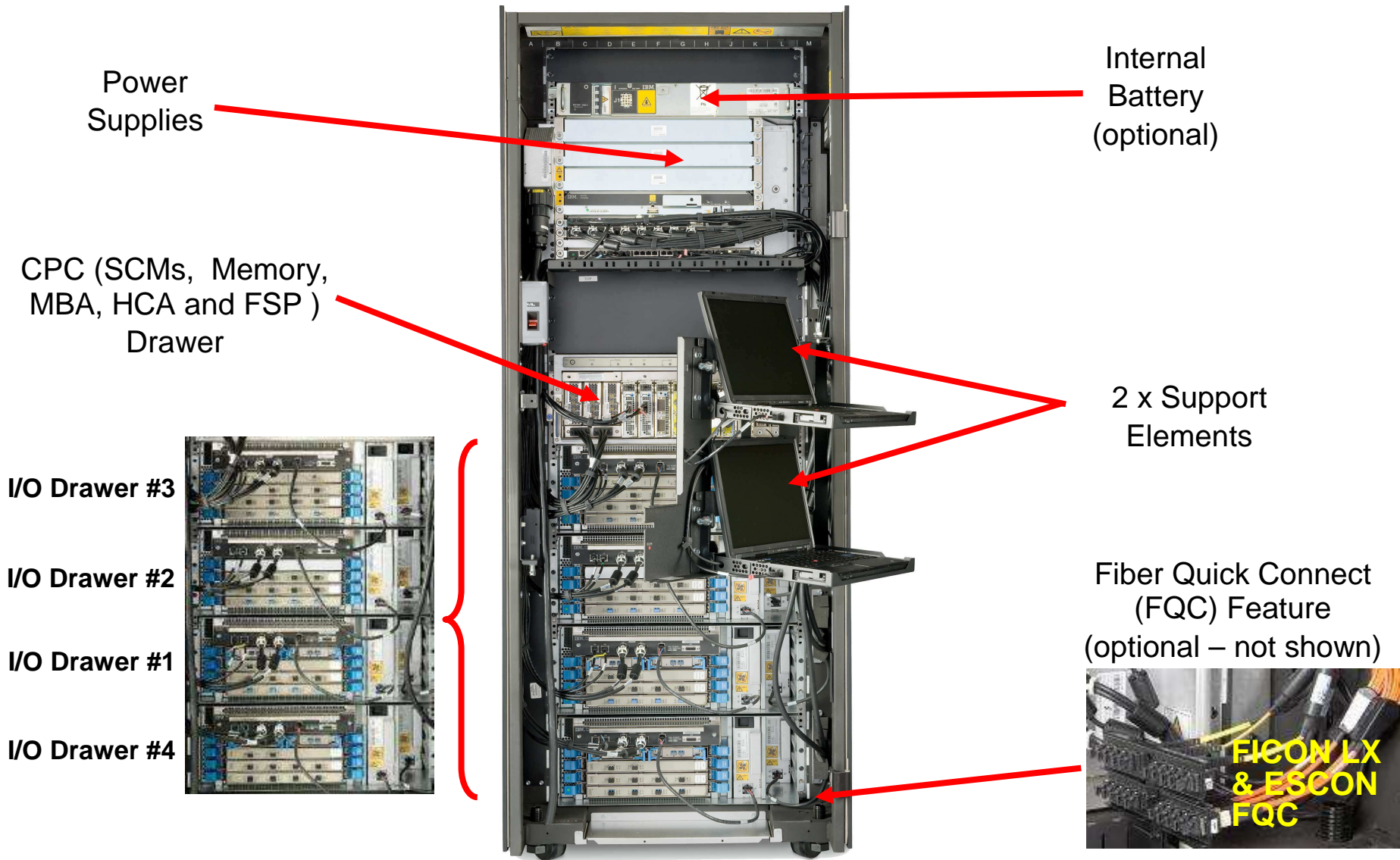

I/O Subsystem – internal host bus interconnect speeds

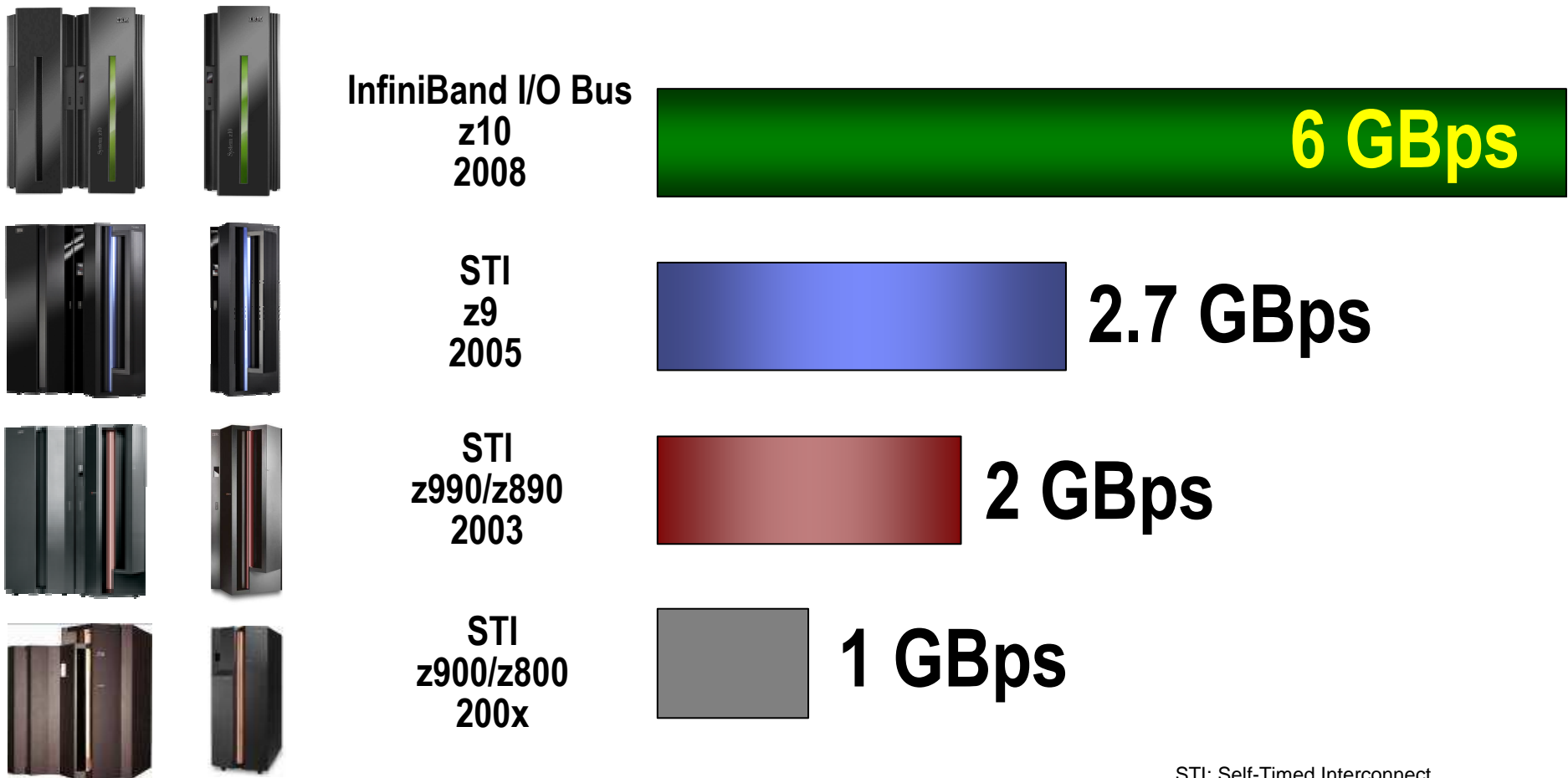

STI: Self-Timed Interconnect



z10 BC I/O connectivity summary

Maximum of 480 CHPIDs, four I/O drawers, 32 I/O slots (8 I/O slots per I/O drawer)

Features	Minimum # of features	Maximum # of features	Maximum connections	Increments per feature	Purchase increments
16-port ESCON	0 ⁽¹⁾	32	480 channels	16 channels 1 reserved as a spare	4 channels
FICON Express4*	0 ⁽¹⁾	32	64/128* channels	2/4* channels	2/4* channels
FICON Express2**	0 ⁽¹⁾	20	80 channels	4 channels	4 channels
FICON Express**	0 ⁽¹⁾	20	40 channels	2 channels	2 channels
ICB-4	0 ⁽¹⁾	6	12 links ^{(2) (3)}	2 link	1 link
ISC-3	0 ⁽¹⁾	12	48 links ⁽²⁾	4 links	1 link
1x PSIFB	0 ⁽¹⁾	6	12 links ⁽²⁾	2 links	2 links
12x PSIFB	0 ⁽¹⁾	6	12 links ^{(2) (3)}	2 links	2 links
OSA-Express3*	0	24	48/96* ports	2 or 4	2 ports/4 ports
OSA-Express2**	0	24	24/48 ports	1 or 2	1 ports/2 port
Crypto Express2*	0	8	8/16 PCI-X adapters	1/2* PCI-X adapters	2* PCI-X adapters ⁽⁴⁾

1. Minimum of one I/O feature (ESCON, FICON) or Coupling Link (PSIFB, ICB-4, ISC-3) required.
 2. The maximum number of external Coupling Links combined cannot exceed 56 per server. There is a maximum of 64 coupling link CHPIDs per server (ICs, ICB-4s, active ISC-3 links, and IFBs)
 3. ICB-4 and 12x IB-DDR are not included in the maximum feature count for I/O slots but are included in the CHPID count.
 4. Initial order of Crypto Express2 is 2/4 PCI-X adapters (two features). Each PCI-X adapter can be configured as a coprocessor or an accelerator.
- * FICON Express4-2C 4KM LX has two channels per feature, OSA-Express3 GbE and 1000BASE-T have 2 and 4 port options and Crypto Express2-1P has 1 coprocessor
- ** Available only when carried forward on an upgrade from z890 or z9 BC. Limited availability for OSA-Express2 GbE features

z10 BC Permanent Capacity Upgrades

- **There are two means by which z10 BC Processor permanent upgrades can be performed. Both are designed to be performed concurrently**
- **Concurrent conversion of previously purchased inactive CPs to active CPs.**
 - Done by the Customer Engineer (CE) through an LICCC only MES ordered through eConfig or by the customer with CIU authorization and Web Tool access (Resource Link)
 - When ordered and installed via Resource Link a paper only follow-up order must be placed through eConfig for billing and AAS record update
- **Concurrent add of CPs from un-purchased PU cores (if available)**
 - Done by the CE through an LICCC only MES ordered through eConfig or by the customer with CIU authorization and Web Tool access (Resource Link)
 - When ordered and installed via Resource Link a paper only follow-up order must be placed through eConfig for billing and AAS record update

z10 BC – Granularity and scalability

Z01	Z02	Z03	Z04	Z05						
Y01	Y02	Y03	Y04	Y05						
X01	X02	X03	X04	X05						
W01	W02	W03	W04	W05						
V01	V02	V03	V04	V05						
U01	U02	U03	U04	U05						
T01	T02	T03	T04	T05						
S01	S02	S03	S04	S05						
R01	R02	R03	R04	R05						
Q01	Q02	Q03	Q04	Q05						
P01	P02	P03	P04	P05						
O01	O02	O03	O04	O05						
N01	N02	N03	N04	N05						
M01	M02	M03	M04	M05						
L01	L02	L03	L04	L05						
K01	K02	K03	K04	K05						
J01	J02	J03	J04	J05						
I01	I02	I03	I04	I05						
H01	H02	H03	H04	H05						
G01	G02	G03	G04	G05						
F01	F02	F03	F04	F05						
E01	E02	E03	E04	E05						
D01	D02	D03	D04	D05						
C01	C02	C03	C04	C05						
B01	B02	B03	B04	B05						
A01	A02	A03	A04	A05						
1-way				5-way						
Specialty Engine	Specialty Engine	Specialty Engine	Specialty Engine	Specialty Engine	Specialty Engine	Specialty Engine	Specialty Engine	Specialty Engine	Specialty Engine	Specialty Engine

z10 BC Model E10

- Granularity designed for flexibility and growth
 - Up to 130 Capacity Settings
- Any to any capacity upgradeability within the Hardware Model
- CBU capability from smallest to largest capacities
 - For CPs
 - All Specialty Engines and SAPs (always full capacity)
- Increased number of Specialty Engines
- Linux and CF only servers
- Capacity Indicator A00 is for systems with IFL(s) or ICF(s) only
 - Additional options for CBU i.e. CBU from A01 to Z05

z10 BC Plan Ahead Memory

- **Provides the ability to plan for non-disruptive memory upgrades**
 - Memory cards are pre-installed based on planned target capacity
- **Pre-installed memory is activated by installing a new LICCC**
 - Orderable via Resource Link by the customer (CIU upgrade)
 - Orderable as an ordinary MES by IBM
 - Memory upgrade orders use the pre-installed memory first
- **Pre-planned memory install**
 - FC 1991 - Charged when physical memory is installed used to track the quantity of physical increments of plan ahead memory capacity
 - Cost part pre-paid
 - Increment size of 4 GB (based on minimum memory purchase increment)
- **Pre-planned memory activation**
 - FC 1992 - Charged when Plan Ahead Memory is enabled based on the amount of Plan Ahead memory that is being activated
 - Remaining cost paid at time of activation
 - Subsequent memory upgrade orders will use up the Plan Ahead memory first
- **Plan Ahead Memory is NOT temporary CoD or CBU memory (Removing memory is disruptive)**

z10 BC Upgrade Paths

- Can enable dynamic and flexible capacity growth for mainframe servers
- Temporary capacity upgrade available through On/Off Capacity on Demand
- Temporary, nondisruptive addition of CP processors, IFLs, ICFs, zAAPs or zIIPs
- New options for reconfiguring specialty engines if the business demands it
- New options for changing On/Off CoD configurations
- Subcapacity CBU engines

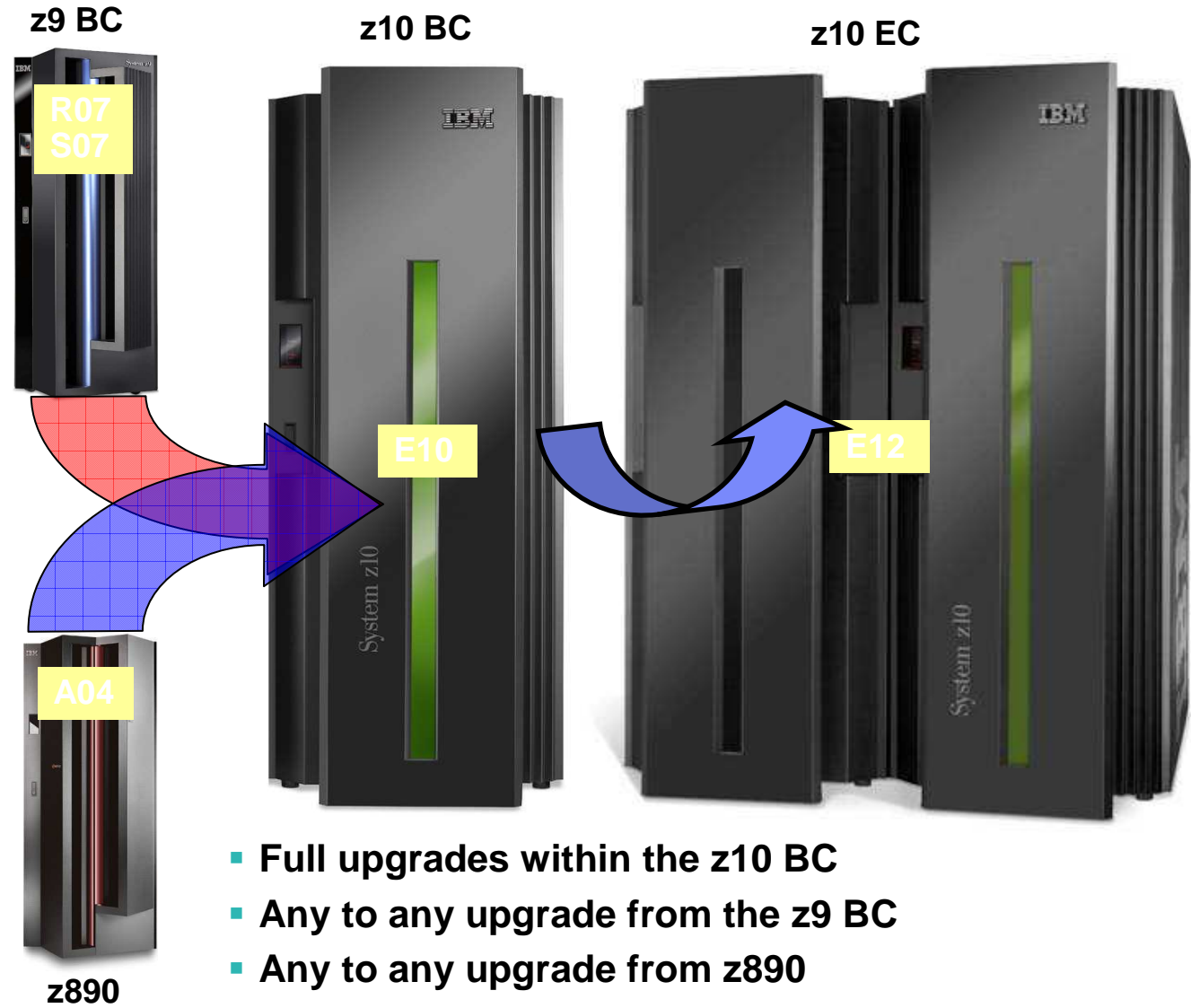

- Full upgrades within the z10 BC
- Any to any upgrade from the z9 BC
- Any to any upgrade from z890
- No charge MES upgrades on IFLs, zAAPs and zIIPs



System z10 BC delivers continued price / performance and affordability for new workloads

Generation to generation price / performance improvements:	z10 BC
Reduction in software charging units, MSUs, ¹ versus z9 BC (1 Millions of Service Units)	10%
Reduction in software charging units, MSUs, versus z890 or z800 / z900	19% or 27%
Maintenance price per MIPS reduction for equivalent capacity ¹	5%
Maintenance price per MIPS reduction with capacity growth ¹	Up to 10%
Performance improvement for Linux (IFLs), Java (zAAPs) and Integrated Information Processors (zIIPs)	Up to 40%
Typical charge for MES upgrades for IFLs, zAAPs, and zIIPs	0
Technology-driven value	z10 BC
Number of capacity settings - 5 Full Uni + 125 Sub-Cap settings	130
50% price reduction on Specialty engines for System z10 BC ^{2, 4}	\$47.5 K
IBM Software charges for zAAP capacity and zIIP capacity	0
62% price reduction on System z10 Memory Prices for new workloads when purchased together with Specialty engines ^{2, 3, 4}	\$2,250 USD

Plus

- **100 percent of IBM mainframes are delivered virtualization ready**
- **System z New Application License Charge (zNALC) pricing metrics for New Workloads**
- **On/Off Capacity on Demand (On/Off CoD) enhancements to better manage volatile business requirements**

1 – Comparisons shown are z9 BC to z10 BC; 2 - Prices in USD, may vary by country; 3 – Limited to 16GB per engine; 4 – Does not include Internal Coupling Facilities (ICFs)

z10 CoD Offerings

- **On-line Permanent Upgrade**
 - Permanent upgrade performed by customer (previously referred to Customer Initiated Upgrade - CIU)
- **Capacity Backup (CBU)**
 - For disaster recovery
 - Concurrently add CPs, IFLs, ICFs, zAAPs, zIIPs, SAPs
 - Pre-paid
- **Capacity for Planned Event (CPE)**
 - To replace capacity for short term lost within the enterprise due to a planned event such as a facility upgrade or system relocation
 - Predefined capacity for a fixed period of time (3 days)
 - Pre-paid
- **On/Off Capacity on Demand (On/Off CoD)**
 - Production Capacity
 - Supported through software offering – Capacity Provisioning Manager (CPM)
 - Payment:
 - Post-paid or Pre-paid by purchase of capacity tokens
 - Post-paid with unlimited capacity usage
 - On/Off CoD records and capacity tokens configured on Resource Link
- **Customer Initiated Upgrade (CIU)**
 - Process/tool for ordering temporary and permanent upgrades via Resource Link
 - Permanent upgrade support:
 - Un-assignment of currently active capacity
 - Reactivation of unassigned capacity
 - Purchase of all PU types physically available but not already characterized
 - Purchase of installed but not owned memory

z10 – Basics of CoD

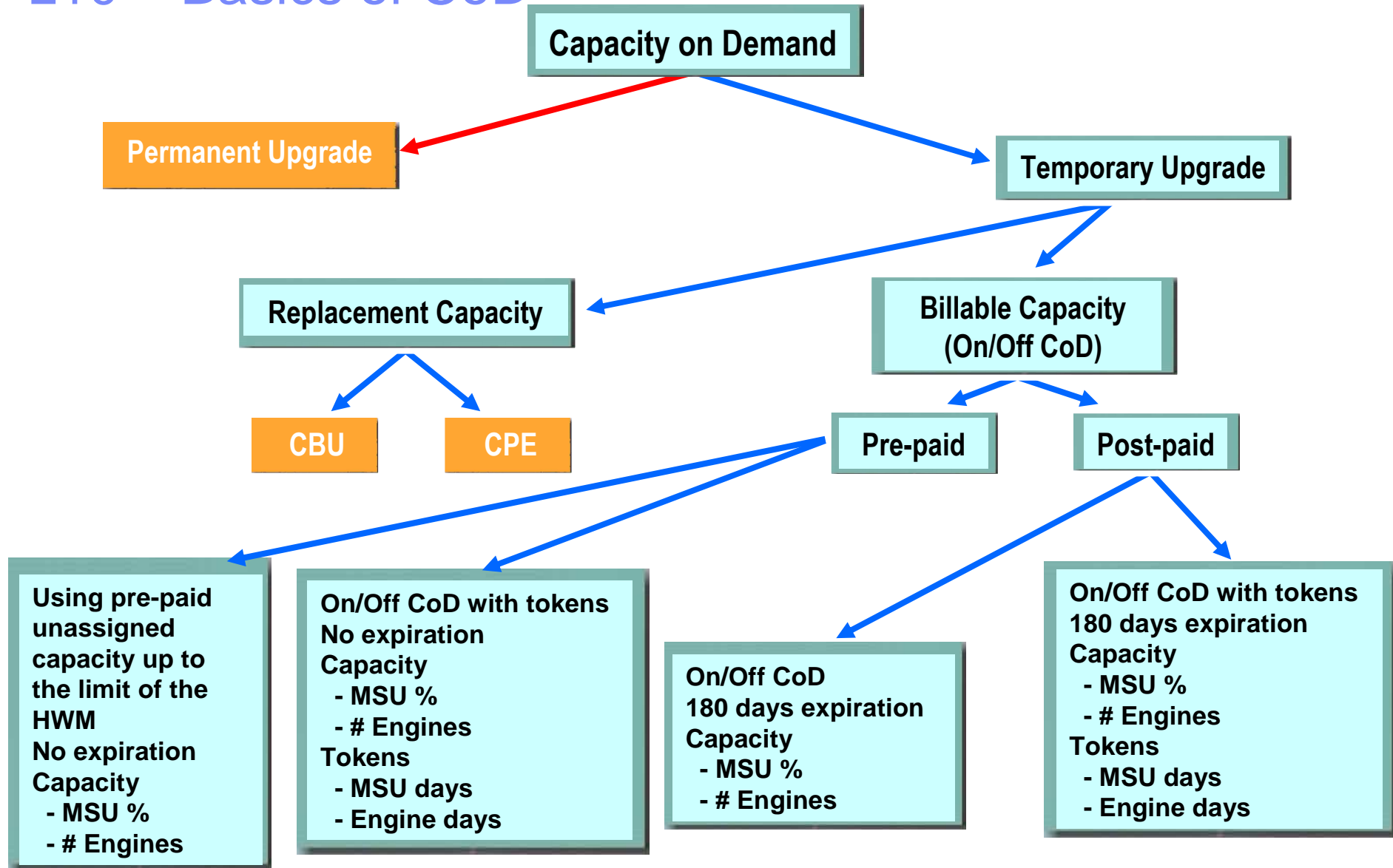



System z z/VM & z/VSE Support Summary



		z890 (WdfM)	z990 (WdfM)	z9 EC	z9 BC	z10 EC	z10 BC	Ship Date	End of Market	End of Service
z/VSE*	3.1	x	x	x	x	x	x	3/05	5/08	7/09
	4.1	x	x	x	x	x	x	3/07	10/08	TBD
	4.2	x	x	x	x	x	x	10/08	TBD	TBD
z/VM	5.2	x	x	x	x	x	x	12/05	6/07	4/09**
	5.3	x	x	x	x	x	x	6/07	9/08	9/10**
	5.4	x	x	x	x	x	x	09/08	TBD	9/11**

Note: z/VM requires Compatibility Support which allows z/VM to IPL and operate on the z10 EC providing System z9 functionality for the base OS and Guests

*z/VSE V3 can execute in 31-bit mode only. It does not implement z/Architecture, and specifically does not implement 64-bit mode capabilities. z/VSE V3 is designed to exploit select features of IBM System z10, System z9, and zSeries hardware.

Note: z/VSE V4 is designed to exploit 64-bit real memory addressing, but will not support 64-bit virtual memory addressing

** Planned. All statements regarding IBM's plans, directions, and intent are subject to change or withdrawal without notice. Any reliance on these Statements of General Direction is at the relying party's sole risk and will not create liability or obligation for IBM.

z/VSE Version 4 Release 1 Highlights

Hardware Support

- z/Architecture mode only⁽¹⁾
 - Up to 8 GB real storage
 - IBM System z9 EC / z9 BC servers
 - IBM eServer zSeries 990, 890, 900, 800
- Open Systems Adapter (OSA)-Express2 and FICON Express4 adapters
- IBM System Storage DS8000 & DS6000™ (both as ECKD™ and FCP-attached SCSI)
- N_Port ID Virtualization (NPIV)

Encryption enhancements

- CPACF enhancements (AES-128)⁽²⁾
- Configurable Crypto Express2 (add accelerator option)
- 2048-bit RSA keys with Crypto Express2
- System managed encryption with an IBM System Storage TS1120⁽²⁾
- Secure FTP⁽²⁾

Security

- Basic Security Manager enhancements
 - Enhanced logging and reporting

1. z/VSE V4 is designed to exploit 64-bit real memory addressing, but will not support 64-bit virtual memory addressing

2. Provided via PTF after GA

New Midrange Workload License Charge (MWLC) pricing metrics

- Based on Capacity Measurement Tool (CMT)
- Attractive full-capacity MWLC price points
- Sub-capacity MWLC option for added price/performance

Interoperability improvements

- SOA and interoperability improvements
- VTAPE enhancements
- VSAM Redirector enhancements
- Backup using Tivoli Storage Manager™ (TSM)
 - TSM running on supported non-VSE server

Networking

- ACF/VTAM for VSE/ESA V4.2 enhancements
 - 31-bit I/O buffer support
- TCP/IP for VSE/ESA enhancements
- OSA-Express2 OSN (Open System Adapter for NCP) support

Fast Service Upgrade from z/VSE 3.1

Requires z/VM 5.2 (or later) if running under VM

z/VSE Version 4 Release 2 Highlights

Servers

- IBM System z10 Enterprise Class (z10 EC), z9 EC, z10 BC and z9 BC
- IBM eServer zSeries 990, 890, 900, and 800

Scalability

- 512 tasks (2X z/VSE V4.1)
- up to 32 GB real processor storage (4X z/VSE V4.1)
- Turbo dispatcher enhancements (CP balancing)
- Parallel Access Volumes (PAV)
- IBM System Storage DS8000 SE FlashCopy®

Security

- Lightweight Directory Access Protocol (LDAP) sign-on support using a new z/VSE LDAP client
- IBM System z10 extensions to CP Assist for Cryptographic Function (CPACF)
- IBM System Storage TS1120 're-keying' function
- Basic Security Manager (BSM) improvements
- Encryption Facility for z/VSE V1.1 as an optional priced feature (also available for z/VSE V4.1)

Enhanced storage options

- IBM System Storage SAN Volume Controller (SVC) access to FCP-attached SCSI disks
- IBM System Storage TS3400 Tape Library and TS7700 Virtualization Engine Release 1.4

Pricing

- MWLC on z10 EC, z9 EC, and z9 BC
- 'traditional' price metrics for other servers

Migration

- Fast Service Upgrade (FSU) from z/VSE V4.1 and z/VSE V3.1

Virtualization

- Requires z/VM V5.2 or later *if* running under VM

Statement of Direction (SOD)

- z/VSE V4.2 will be the last version/release of VSE to ship CICS/VSE® V2.3

z/VSE V4.2 Additional Enhancements

Planned availability: July 17, 2009

- **Parallel Access Volume (PAV)** feature of IBM System Storage series DS8000 and DS6000
 - **I/O performance improvements**

- **IBM DS8000 Full Disk Encryption**
 - **Highest security for business-critical data**

- IBM Virtualization Engine TS7700 Release 1.5 including support for the **TS7720 virtual tape system**
 - **Support includes disk-only virtual tape systems with up to 70 TB of disk cache**

- Encryption Facility for z/VSE V1.2 supporting the **OpenPGP** format
 - **Flexible and highly secure data exchange with business partners and peers**

- **IBM Rational COBOL Runtime** for z/VSE V7.5
 - **Execute modern Enterprise Generation Language (EGL) developed with Rational Business Developer**

- **IBM WebSphere MQ** for z/VSE V3.0
 - **Improved interoperability on distributed and mainframe platforms**

Parallel Access Volume (PAV)

- **Allows a z/VSE V4.2 host to access a single ECKD disk volume with multiple concurrent requests**
 - multiple addresses (alias) to a single logical device
 - enables more than one I/O operation to a single logical device
 - may reduce device queue delays
 - volume sharing – not file sharing
- **PAV is an optional, licensed feature of DS8000 and DS6000** **IBM**
 - no changes needed for application programs
- **Examples of PAV candidates**
 - VSAM catalogs, shared clusters, libraries
 - spool files, work files, log files
- **Potential benefits include possibility of improved performance/throughput**
 - multiple jobs, multiple partitions, CICS
 - gains are *highly dependent on workload*

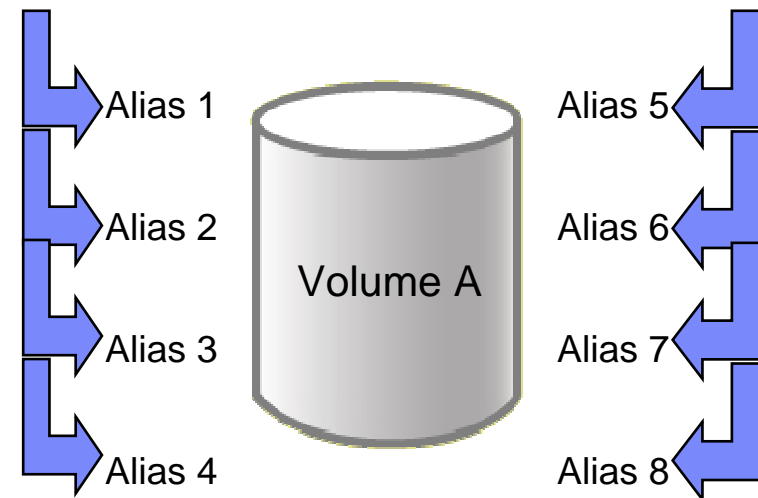

Full Disk Encryption on DS8000

- **Encrypted data on DS8000 series storage controller**
 - Capability to install encrypted 146 GB, 300 GB, and 450 GB 15,000 rpm Fibre Channel drives
 - Full Disk Encryption drive sets are optional to DS8000 series
 - Available only as plant order
 - Transparent to applications
 - Can be used by z/VSE V3.1 or later

- **Helps to mitigate the threat of**
 - Theft
 - Mis-management
 - Loss of critical data

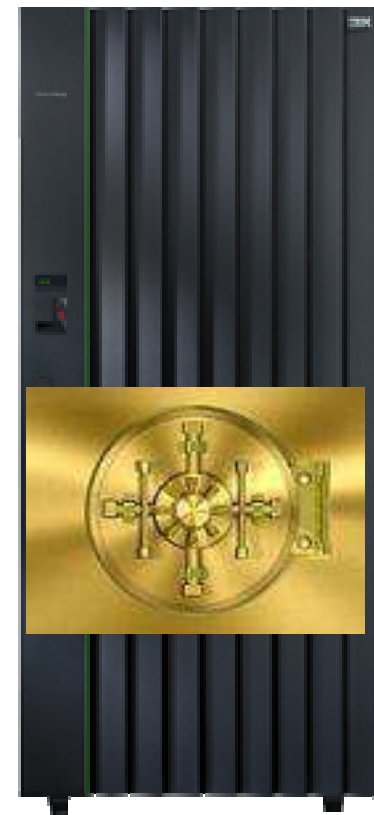

IBM System Storage TS7700 Virtualization Engine Release 1.5

- **TS7720 is a new member of IBM's family of virtualization products**
 - Virtual tape system designed for use in a mainframe environment
 - Tape Volume Cache capacity up to 70 TB but without a physical tape library for back-end processing
- **TS1130 Model E06 and Model EU6 Tape Drive support**

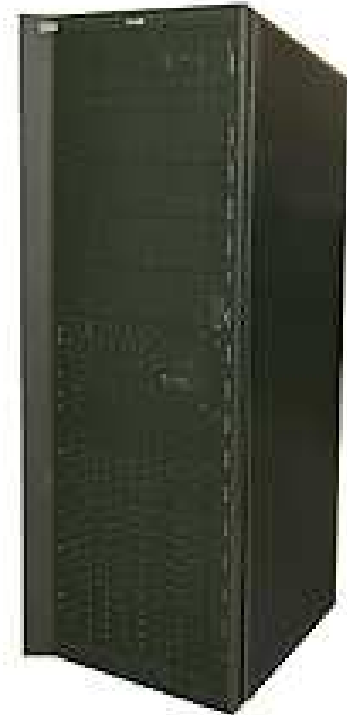

The TS7700 Virtualization Engine tape solution is well suited for

- Disaster recovery
- Data consolidation
- Data protection
- Data sharing

Encryption Facility for z/VSE V1.2 (EF)

- **OpenPGP**
 - Complies with selected OpenPGP standard (RFC 4880) requirements
 - Encryption of SAM files, VSE/VSAM files, VSE library members, tapes, or virtual tapes
- **Choice of two formats:**
 - System z format (introduced with EF for z/VSE V1.1) - compatible with EF for z/OS
 - OpenPGP - compatible with other products that are OpenPGP-compliant
- **EF is an optional priced feature for VSE Central Functions V8**
 - Requires z/VSE V4.1 or later
 - MWLC-eligible
- **Exploits hardware encryption technology: CPACF (CP Assist for Cryptographic Function) and Crypto Express2**

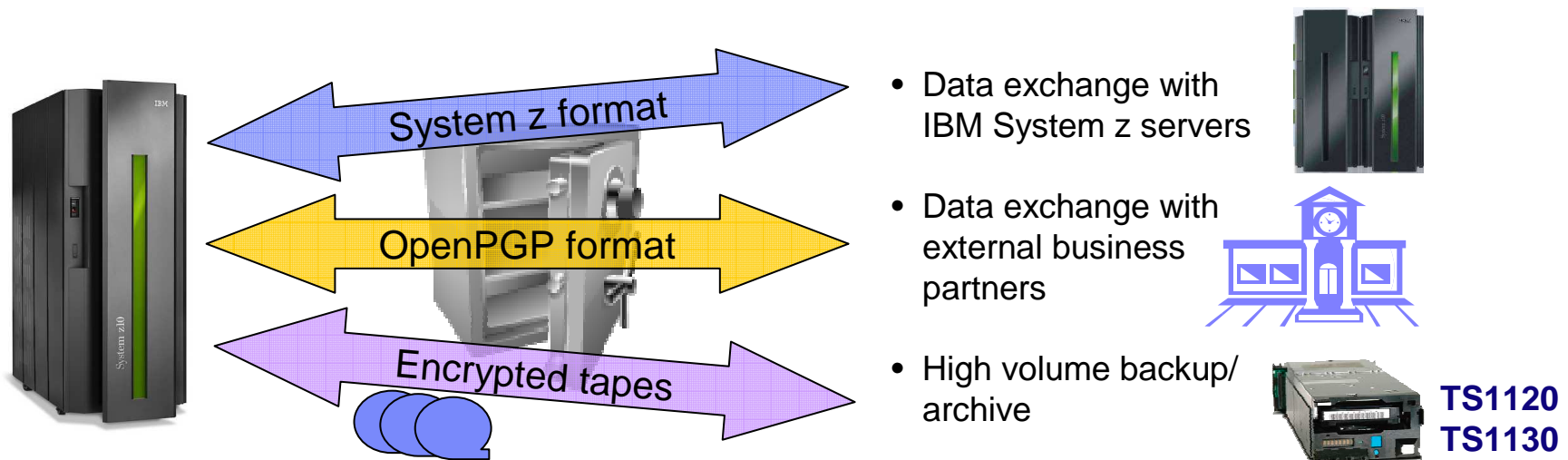

z/VM Support for Specialty Processors

- **z/VM 5.3 introduced support for zAAP and zIIP specialty processors**
 - System z Application Assist Processors (zAAPs) – provide an economical Java execution environment for z/OS and z/OS.e
 - System z Integrated Information Processors (zIIPs) – designed to help improve resource optimization and lower the cost for eligible z/OS and z/OS.e workloads by offloading software system overhead from standard Central Processors (CPs); this includes certain DB2 processing
- **z/VM support is provided for z/OS guest exploitation**
 - Offers additional hardware support for z/OS-on-z/VM development and test support
- **Two levels of z/VM support:**
 - Simulation support
 - z/VM dispatches virtual zAAPs and zIIPs on real CP engines
 - Only possible if the underlying hardware is capable of supporting the real engine type
 - Does not require activation of real specialty engine(s) within the mainframe server
 - Virtualization support
 - z/VM dispatches virtual zAAPs and zIIPs on corresponding real specialty engines
- **Consistent with z/OS, there are no z/VM license fees associated with real zAAP or zIIP processors**

z/VM 5.4

- **Increased flexibility with support for new z/VM®-mode logical partitions**
 - CP, IFL, zAAP and zIIP can be mixed in one LPAR
- **Dynamic addition of memory to an active z/VM LPAR by exploiting System z® dynamic storage-reconfiguration capabilities**
 - Adding preplanned Storage on demand
- **Enhanced physical connectivity by exploiting all OSA-Express3 Adapter**
 - support for all 4 Port
 - support for QDIO data connection isolation
 - support for Link Aggregation
- **Operation of the SSL server in a CMS environment**
 - no Linux based SSL Server required
- **Systems management enhancements for Linux and other virtual images**
 - PAV (Guest and CMS)
 - Virtual FICON Protocol
- **Hardware Support**
 - 3592 Tape Controller J70 and C06
 - 3592 Tape Drives Models J1A, E05, and E06,

z/VM and Dynamic Memory Upgrade

- **z/VM V5.4 exploits dynamic memory reconfiguration**
- **Users can non-disruptively add memory to a z/VM LPAR**
 - Additional memory can come from: a) unused available memory, b) concurrent memory upgrade, or c) an LPAR that can release memory
 - Memory *cannot* be non-disruptively removed from a z/VM LPAR
- **z/VM virtualizes this hardware support for *guest machines***
 - Currently, only z/OS and z/VM support this capability in a virtual machine environment

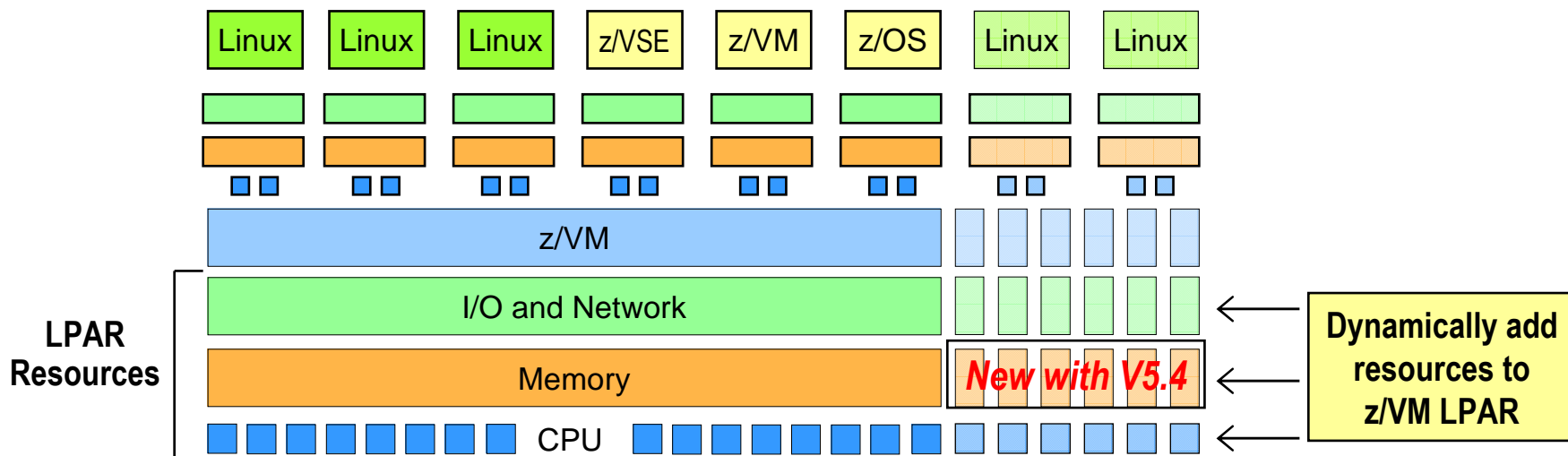

z/VM-Mode LPAR Support for IBM System z10

- **New LPAR type for IBM System z10: z/VM-mode**
 - Allows z/VM V5.4 users to configure all CPU types in a System z10 LPAR
- **Offers added flexibility for hosting mainframe workloads**
 - Add *IFLs* to an existing standard-engine z/VM LPAR to host Linux workloads
 - Add *CPs* to an existing IFL z/VM LPAR to host z/OS, z/VSE, or traditional CMS workloads
 - Add *zAAPs* and *zIIPs* to host eligible z/OS specialty-engine processing
 - Test integrated Linux and z/OS solutions in the same LPAR
- **No change to IBM software licensing**
 - Software continues to be licensed according to CPU type

